

THE iX3

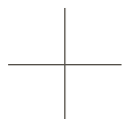

#bornelectric





CONTENTS

EXTERIOR AND INTERIOR DESIGN.....	04 /05
EDITORIAL: EXTREME ELECTROMOBILITY.....	06 /07
ELECTRIC DRIVING PLEASURE.....	08 /09
CHARGE AT HOME.....	10 /11
PUBLIC CHARGING.....	12 /13
EDITORIAL: THE FLOW OF A NEW TIME.....	14 /15
CONNECTIVITY AND DRIVER ASSISTANCE.....	16 /17
TECHNICAL VALUES.....	18 /19
SUSTAINABILITY.....	20 /21



YOU DON'T DRIVE IN A NEW
 And for the brave, every moment is
 DIRECTION ON OLD ROADS.
 the right moment to set off.



THE NEW BMW iX3 ELECTRIFIES ALREADY VISUALLY:

The kidney grille inner frame in the BMW i Blue* signature colour emphasises the closed kidney grille, while a mesh-like structure creates an unique BMW i look. Side sills with a blue accent and a trim element* on the Air Breather give the side view a dynamic and powerful presence. Instead of conventional tailpipes, a diffuser with large blue inlays* is an expressive sign of the vehicle's innovative drive.

The interior of the new BMW iX3 impressively demonstrates how comfortable, valuable and generous an innovative driving experience can be. Design highlights such as accents in the sport leather steering wheel, detailing on the gear selector lever, the BMW iX3 badge in the centre console or the backlit blue Start/Stop button spread a modern, luxurious ambience that fascinates at first glance.

* The availability of some equipment features and functions depends on engine variants or additional options. The market and production availability may vary. You can find detailed information about terms, standard and optional equipment at www.bmw.com or at your BMW Partner.

► Icy cold, shimmering heat: Before series launch, BMW tests its electric vehicles under the toughest conditions on the Arctic Circle in Sweden and in the South African Kalahari Desert to ensure optimum range and performance.

Arjeplog, 56 kilometres south of the Arctic Circle. –26 °C. Barely bright, daylight disappears again on the grey horizon just a few hours later. A lonely place. Suddenly dry powder snow flies up. A new electric BMW prototype accelerates at high speed around the bend and over the snow-smooth road surface, which can only be assumed to be a road. Welcome to the BMW winter tests in the icy wasteland of Lapland, in the north of Sweden. Here, every BMW has to prove that it functions perfectly even under extreme conditions.

The new electric BMW model rushes across the mirror-smooth ice surface of a kilometre-long lake, brake lights come on, a short swerve, the vehicle comes to a halt – to start again immediately, to accelerate, to brake. These are ideal conditions for testing all the components of the BMW eDrive technology in detail, because its components make special demands from BMW engineers: For example, the electrochemical processes within the high-voltage battery run differently depending on the ambient temperature – a fact that is being examined in great detail here to ensure the highest possible performance and reliability in the production vehicle.

Change of scenery. Kalahari, Southern Africa. Unpaved sand, gravel and scree tracks. Extreme heat and solar radiation. Permanent dust formation. At the highest temperatures, the integrated cooling concept for the lithium-ion battery, the electric motor and the power electronics must prove its worth. This is just one of the tests in the so-called hot-climate test, which is part of the comprehensive development and test program of the series development. In both the

► In the desert region in the northwest of South Africa, the drive and chassis components can be tested and tuned to each other under extreme conditions.



► The frozen lakes offer ideal test conditions: Due to the low coefficients of friction, reproducible test runs at the limits are possible.

winter and heat tests, the prototypes are subjected to the stresses and strains of a complete vehicle life practically in fast motion.

In extreme plus and minus temperatures, driving on ice, snow, desert sand and gravel, experienced BMW engineers use powerful measuring technology on board to register all the vehicle's responses to a wide range of weather conditions, road surfaces and other influences. At temperatures that would cause any mobile phone battery to discharge in no time at all, the powerful integrated cooling concept of the high-voltage battery proves its worth. The drive and chassis components are also tested and tuned to each other under extreme conditions. For hours, a new pre-series model is repeatedly heated in the sun and then cooled

down. The developers not only test the operability of the electrical systems, but also the temperature resistance of the materials in the interior. Nothing must creak or crackle here – neither at high nor low temperatures. The dustproofness of bonnets, doors and flaps is also extensively tested in the desert. When driving thousands of kilometres through dunes, savannahs and bush land, a new BMW may kick up a lot of dust – but it must not let any of it get inside.

INSPIRATION LEAVES
 And those who make the unexpected
 NOTHING BUT
 possible are on the best
 NEW IDEAS.
 way to the destination.



The extremely dynamic design in black high-gloss with five aerodynamically optimised aluminium inlays turns the new 20" aerodynamic wheel 843 Bicolor^{1,2} into a visual highlight – with less weight and higher aerodynamics at the same time. This results in lower consumption and a higher range.

► Electric motor of the newest generation: The drive in the new BMW iX3 manages completely without rare earth metals.

Powerful thrust plus maximum efficiency plus maximum driving pleasure: In the new all-electric BMW iX3, a modern drive of the latest BMW eDrive generation combines the best of all worlds. The innovative electric motor offers an output of **210 kW (286 hp)**, which can be optimally accessed at any time by means of intelligent energy management. A one-speed transmission transforms it into powerful, impressive acceleration without any gear changes: From the first moment, a breathtaking torque of **400 Nm** is available without lag. The superior power of the electric motor is transferred to the rear wheels in a targeted manner. This not only promotes a higher range, but also creates the inimitably dynamic driving sensation of a typical BMW rear-wheel drive, which turns every drive into a fascinating experience of euphoric driving pleasure.



¹ Available as optional equipment.

² Available as standard for Impressive model.



BECAUSE EVERY
 Boundless freedom
 NEW DESTINATION
 makes a new
 EXPANDS YOUR
 beginning out of
 OWN BOUNDARIES.
 every journey.

COMFORTABLE AND SAFE INTO THE FUTURE: CHARGING AT HOME.

For charging at home, **BMW Charging** offers you everything you need – even as a practical package solution on request. With the new **Flexible Fast Charger**¹, you can charge your new BMW iX3 at a domestic socket outlet or – with an available adapter – at a more powerful industrial socket. The quick charger is particularly easy to operate and can be used flexibly on the move thanks to its

waterproof, compact and robust housing. Do you need a suitable power outlet? Simply book the professional installation with it. This also applies to the **BMW Wallbox Essential**¹ with an even higher charging capacity of up to 11kW, a reduced design with a functional LED bar or alternatively the **Smart Wallbox**¹, which also offers additional services for intelligent charging. Both wallboxes set a modern

sign in or at the house for a new, sustainable way of living mobility.



¹ Equipment available as an option from Original BMW i Accessories.

- ▶ A short stop for maximum flexibility: Thanks to the high charging power, the range increases in just a few minutes.



ALWAYS FULL OF ENERGY: PUBLIC CHARGING.

No matter how boundless your ideas are – with the new BMW iX3 they become reality. Its high range of up to 460 kilometres¹ reliably guides you to your destinations in everyday life. And if you want to go even further, extensive charging options are also available to you on the road.

Regardless of where and how you want to charge your new BMW iX3 – **BMW Charging** offers you tailor-made products and services. For public charging, BMW Charging and your **BMW Charging Card** supplied with your vehicle give you access to a network of over 450,000 charging points worldwide. These include numerous high power charging stations, for example those of our cooperation partner IONITY, on the main traffic routes throughout Europe. With its charging capacity of up to 150 kW, the new BMW iX3 can be charged up to 80 per cent in around 34 minutes². Breaks on journeys with your new BMW iX3 are now even shorter. If you don't want to charge your new BMW iX3 on the road at a high power charging station but at a charging point using alternating current (AC) or direct current (DC) from the BMW Charging network, you will need the **charging cable for public charging (mode 3)**, which is included as standard equipment with the new BMW iX3.

¹ Range depends on various factors. In particular: personal driving style, route characteristics, exterior temperature, heating/air conditioning, pre-conditioning and the chosen equipment.

² Dependent on local electricity infrastructure and the selected optional equipment



THE FLOW OF A NEW TIME.

► A day in an electric BMW of the current generation promises pure excitement – no matter how you organise your day.

8:40 a.m. Inside the house, a hot espresso wakes the spirits, outside on the new all-electric BMW, the BMW Wallbox does the job – the high-voltage battery is charged faster than a normal domestic socket outlet ever could. The BMW smartphone app lets you keep an eye on the current charging status at all times. You and your electric BMW: Ready to go!

It's cold out there. It's a good thing that the departure time has been set to 9.00 a.m. via the BMW smartphone app – this means that the high-voltage battery and the interior are already optimally preconditioned via the domestic power supply system when the journey begins. Clever – so you need to heat less when you're on the move, which saves on range. When you approach, the vehicle door is already unlocked with the Digital Key on a compatible smartphone, so get in and start – it couldn't be smarter. Quickly select the desired SPORT driving mode by voice using the BMW Intelligent Personal Assistant and off you go!

10:15 a.m. The navigation system still shows 85 km to the destination. The blue circle on the navigation map shows at a glance that the range is not sufficient up to that point. Conveniently, Connected Charging immediately shows you possible charging stations on the way in the Control Display – including the expected charging time. You can navigate to the nearest charging station displayed of the public BMW Charging network. Use the charging time for a spontaneous purchase and enjoy a cappuccino at your favourite café, which your BMW shows you nearby. Did you know? The BMW Charging Card also gives you access to high power charging points from BMW partner company IONITY and other providers along motorways when you are travelling long distances. "Refuelling" of electricity for up to 100 kilometres is done there in about ten minutes for all electric vehicles of the current generation.

2:30 p.m. The meeting was a complete success! Because the afternoon is free and you have your sports gear and running shoes with you, all it takes is a quick call to a friend whose home is on the way back and a jogging appointment has been made. When you ask yourself how you can achieve greater range, the BMW Intelligent Personal Assistant advises you to activate the ECO PRO mode before you announce your arrival time with the BMW smartphone app and enjoy the driving and anticipation of the joint run. Before you set off, you quickly connect your BMW and the high voltage socket at home using the Flexible Fast Charger – this way, the charger gets the maximum number of kilometres out of your spontaneous running meeting.

6:00 p.m. Almost silently, the BMW rolls under the carport. The high-voltage battery still has enough power for many more kilometres – but tomorrow there will be a longer trip again. This is why you connect your vehicle to the BMW Wallbox – charging is faster and more convenient than ever. In addition to access to many charging functions and your charging history, you can also automatically supply your vehicle with energy in the most favourable period of time depending on the energy tariff and departure time – and of course with electricity from your own solar system in a particularly sustainable manner. One thing is certain after this day: Even electrically, a BMW is always a BMW – and another day of comfortable and dynamic driving pleasure is already in the starting blocks.

Some of the functions and equipment mentioned in the text are optional equipment and may require the presence of other equipment. The availability of equipment features may vary in different countries. Your local BMW Partner is available to provide further details.

Some ConnectedDrive Services may differ between countries. Please consult your local BMW partner for more information.



REAL INNOVATION
 Every task deserves
 OCCURS WHEN IDEAS
 to be solved
 BECOME USEFUL.
 with pleasure.

The innovative services from **BMW ConnectedDrive** open the gate to the digital world of BMW. These include, for example, the online-based and application-optimised navigation services of **BMW Maps*** and the intelligent digital services of **Connected Charging***. Via the **BMW smartphone app¹**, you can check the charging status at any time – whether in the vehicle or at home. You can plan your journey optimally, including proactive suggestions for charging stops with additional information on charging stations and Points of Interest in the vicinity. With **smartphone integration^{2,3}**, your vehicle supports Apple CarPlay® and Android Auto® by means of a wireless connection between your smartphone and the vehicle, allowing you to conveniently use familiar functions and various apps in your new BMW iX3.

Always by your side when driving: the standard **Driving Assistant Professional**. Its camera-based and radar-based systems help you, for example, to maintain speed, lane and distance or to brake safely in challenging situations. After the journey, the **Parking Assistant Plus^{2,4}** automatically parks for you even in tight spaces and offers many other functions that make parking and manoeuvring easier, such as the **Reversing Assistant** and **Surround View**.

► Relevant, brilliant, high-resolution: the 10.25" Control Display of the standard BMW Live Cockpit Professional.

EVERY DAY BRINGS CHALLENGES –

and with the new BMW iX3, you master every one of them with ease. An extensive range of intelligent assistant systems and **ConnectedDrive Services*** provide support.

For example, the **BMW Intelligent Personal Assistant*** is always at your side as a virtual passenger and not only explains the various functions of your new BMW iX3, but also easily finds the nearest charging station and calculates the route to it.

Some ConnectedDrive Services may differ between countries. Please consult your local BMW partner for more information.

* The availability of some equipment features and functions depends on engine variants or additional options. The market and production availability may vary. You can find detailed information about terms, standard and optional equipment at www.bmw.com or at your BMW Partner.



¹ This feature is only available in conjunction with ConnectedDrive Services and a compatible smartphone. The availability and functions of the smartphone app depend on the vehicle model and may vary depending on the market. Detailed information is available at www.bmw.com
² Available as optional equipment.
³ Smartphone Integration is permanently available in the vehicle. It includes Apple CarPlay and Android Auto. Android Auto linking is only possible in

conjunction with a BMW Live Cockpit. Due to possible future technical developments (e.g. of mobile phones), the usability of the Apple CarPlay or Google Android Auto service cannot be guaranteed permanently. CarPlay is a trademark of Apple Inc. Android Auto is a trademark of Google LLC.
⁴ The driver is responsible for constantly monitoring the automated parking procedure in accordance with local road laws.

TECHNICAL VALUES

BMW iX3

Weight		
Unladen weight EU ¹	kg	2260
Maximum permissible weight	kg	2725
Permitted load	kg	540
Permitted trailer load, unbraked ²	kg	750
Permitted trailer load, braked, max. 12 % gradient/max. 8 % gradient ²	kg	750/750
Luggage capacity	l	510 – 1560
eDrive motor		
Max. output	kW (hp)	210 (286)
Max. torque	Nm	400
Lithium-ion high-voltage battery		
Battery type/net battery capacity	kWh	Li-ion/73.8
Maximum electric range ³	km	520
Charging time (0 – 80 %) ⁴	h	0.6
Power transmission		
Type of drive	–	Rear-wheel drive
Standard transmission	–	Steptronic
Performance		
Top speed	km/h	180
Acceleration 0 – 100 km/h	s	6.8
Consumption ^{5, 6} – All engines conform to the EU6 standard		
Consumption range, combined	kWh/100 km	17.5 – 17.8
Combined CO ₂ emissions	g/km	0
Wheels/tyres		
Tyre dimensions		245/50 R19 W
Wheel size		8Jx19
Material		Light alloy

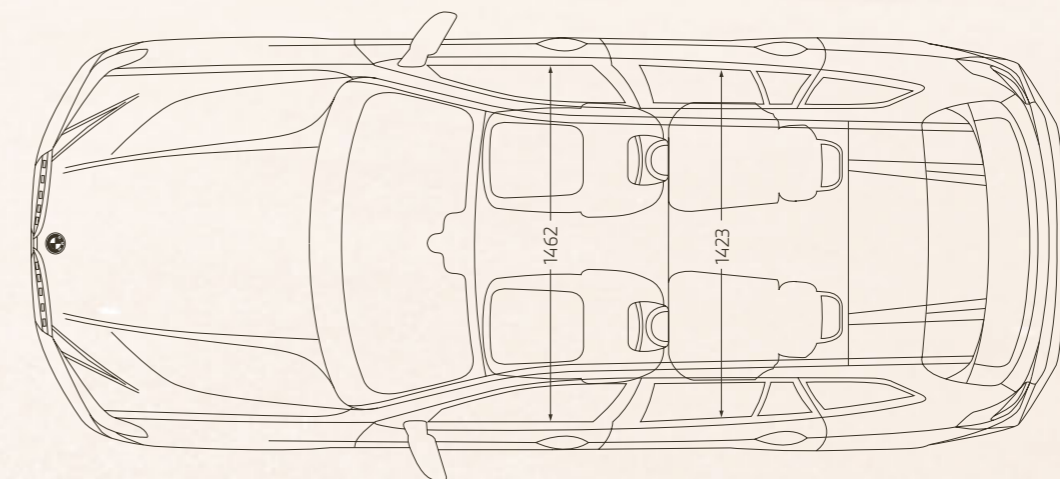
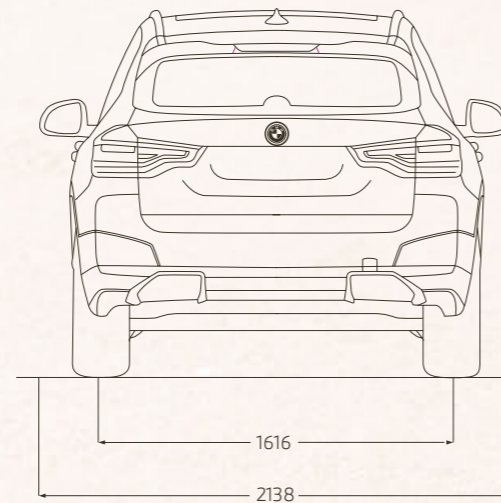
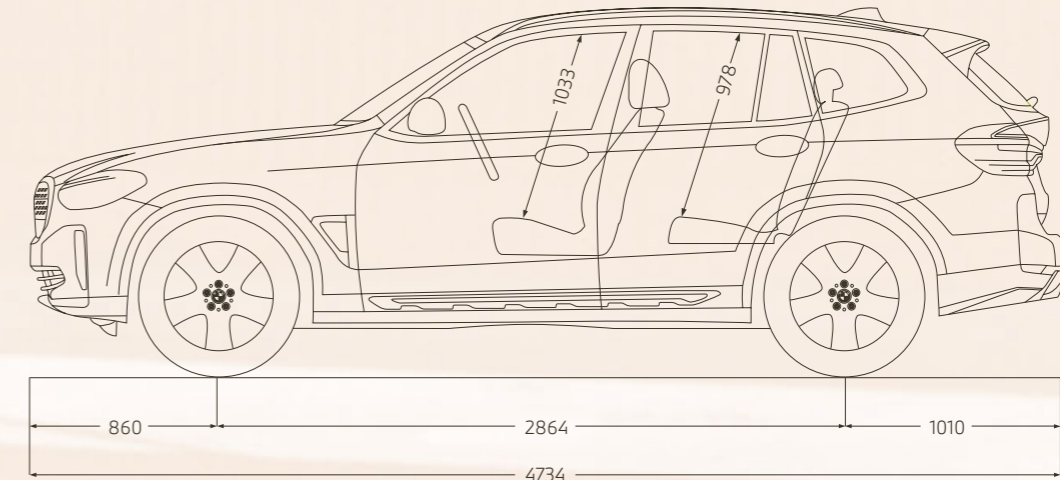
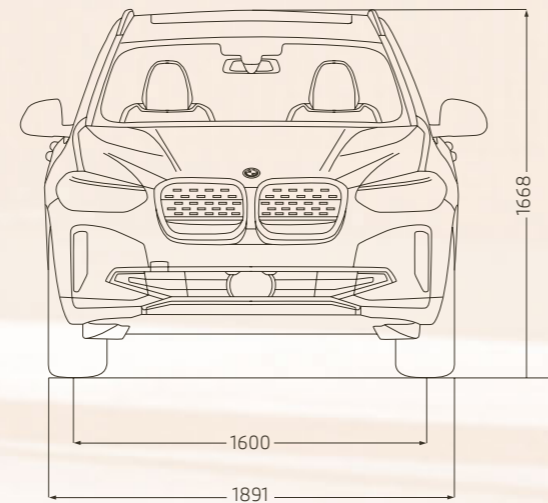

All dimensions in the technical drawing are given in millimetres.
 The figures for performance, fuel consumption and CO₂ emissions refer to vehicles with standard transmission.
 CO₂ emissions caused by the production and supply of fuel or other energy sources are not taken into account when determining CO₂ emissions according to Directive 1999/94/EC.

¹ The figures quoted are based on a driver weight of 75 kg. The unladen weight applies to vehicles with standard equipment. Optional equipment may affect the weight of the vehicle, the payload and the top speed if the equipment has an impact on the vehicle's aerodynamics.
² The actual total weight of the trailer must not exceed the maximum trailer load, taking into account the maximum tow bar download.
³ Range depends on various factors. In particular: personal driving style, route characteristics, exterior temperature, heating/air conditioning, pre-conditioning.
⁴ Dependent on the local electricity infrastructure. Value determined with DC ECE 150 kW
⁵ The data for fuel consumption, CO₂ emissions and energy consumption are determined in accordance with the measurements processes as defined by European Regulation (EU) 2007/715 in the applicable version. Data refer to a vehicle with base-level equipment in Germany, and the ranges account for differences according to the selected wheel and tyre size and the optional equipment and may change during the configuration process. Figures have been determined on the basis of the new WLTP test cycle and have been converted back into NEDC figures for comparability. [For these vehicles, values other than those specified here may apply for the assessment of taxes and other vehicle-related charges that are (also) based on CO₂ emissions.]
⁶ The combined consumption range depends on the selected wheel and tyre sizes.

CONSUME LITTLE, ACHIEVE EVERYTHING: SUSTAINABILITY.



Sustainability is in the DNA of BMW i – long before the driving pleasure begins. From the selection and processing of raw materials, through the actual production in our plants, to recycling: BMW i is constantly developing electric mobility to keep the ecological footprint as small as possible. This makes driving all the more enjoyable – even for our future generations.

TOGETHER ON THE WAY TO THE FUTURE –
SUSTAINABILITY AT BMW, FIVE TIMES IN A NUTSHELL.

Being a **visionary** also means taking the right path step by step. This is why we have been supplying our European plants with 100 percent CO₂-free electricity since 2017 – and plan to source energy exclusively from renewable sources by the end of 2020.

Resources are valuable. We believe in using only what we really need and making the most of what we use. This is why BMW uses recycled materials and renewable resources wherever it is technically possible and economically sensible.

Innovation is our driver. In this way we achieve our goals with fewer resources. For this reason, from 2021, BMW will completely stop using rare earth metals in the production of electric vehicles.

Substance is at the core of our efforts. With every step we take, we try to become better. Every electrified BMW model, from the procurement of raw materials, through assembly and use, to recycling, produces less CO₂ emissions in total than its traditionally powered counterpart – and this can even be reliably proven.

Respect comes first for us – for our planet and its people. Compliance with human rights and environmental standards along the entire supply process has therefore long been a basic requirement for BMW.

This makes driving all the more enjoyable – even for our future generations. Discover more at <https://www.bmwgroup.com/en/responsibility.html>

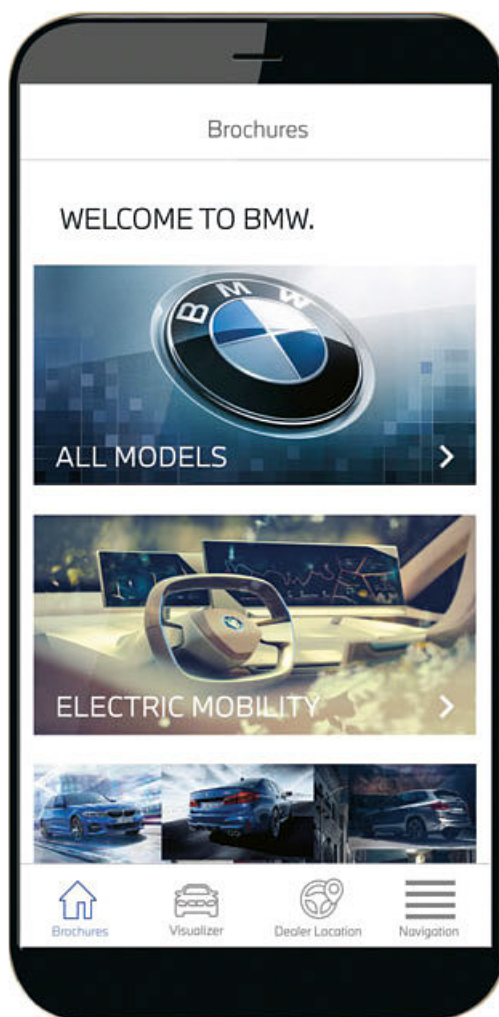

YOUR BMW BROCHURES APP.

DOWNLOAD NOW THE BMW BROCHURES APP FROM YOUR APP STORE AND DISCOVER DRIVING PLEASURE!

BMW iX3:

BMW eDrive electric motor, 210 kW (286 hp), 20" aerodynamic wheels 843 Bicolor with mixed tyres, exterior colour in Mineral White metallic, Sport seats in leather Vernasca Mocha with decorative stitching Black, interior trim finishers Aluminium fine cutting with highlight trim finisher Pearl Chrome.

This brochure describes the model, features and configuration options in vehicles available to the international/global market. There may be deviations from the features and configuration options described in this brochure, in terms of the standard and optional equipment for the model specified for the South African market. For more precise information about country-specific vehicle versions, please contact your local BMW dealership or visit www.bmw.co.za. Subject to change in design and equipment. E&OE.

Of course, each vehicle is designed for economical recycling after its long-running life. You can find more information regarding your end-of-life vehicle on our website www.bmw.de/recycling.

© BMW AG, Munich, Germany. Not to be reproduced wholly or in part without prior written permission of BMW AG, Munich.

411 009 269 24 2 2020 CB. Printed in Germany 2020.